

RY LIFT TRUCKS onsek & bunke®



Onsek Bunke İş Makineleri Otomotiv San. ve Tic. A.Ş
Ürnlü Mh. Ürnlü Cd. No:7/1 Nilüfer / BURSA
Tel: 0850 304 07 80

operasyon@onsekbunke.com
www.onsekbunke.com.tr



Onsekbunke, bu broşürde ayrıntıları verilen renk, ekipman veya özelliklerde herhangi bir bildirimde bulunmaksızın değişiklik yapma hakkını saklı tutar. Sürekli geliştirilen ürünlerin konfigürasyonları broşürlerde farklılık gösterebilir. Baskı hatalarından Onsekbunke sorumlu değildir.

ROYAL Lityum Bataryalı Elektrikli Transpalet ve Elektrikli İstifleyiciler



ALMAN AC SÜRÜŞ TEKNOLOJİSİ



Güçlü Alman Schabmueller bakım gerektirmeyen AC Tahrik motoru, Alman Kordel dişli kutusu, Intoçe fren ve wicke tahrik tekerleği ile birlikte işletme maliyetlerini azaltmak için en iyi performansı, verimliliği ve güvenilirliği sağlar! Talebiniz ne olursa olsun, AC Sürücü her zaman doğru yanıtı verir.



ROYAL ELEKTRİKLİ TRANSPALET

- Ergonomik, kompakt ve güvenli uzun performans
- Güvenilir ve güçlü
- Güçlü, bakım gerektirmeyen motor
- En kaliteli markalardan temel bileşenler



ÇEŞİTLİ SEÇENEKLER

Yük arkalığı
Yandan pil değişimi
İstek üzerine farklı çatal versiyonları
Giriş silindirleri standarttır.

CANBUS Teknolojisi

CANBUS teknolojisi, daha az kablolama nedeniyle daha güvenilirdir.
Bakım için CANBUS teknolojisi, analiz ve ayarlamaları kolaylaştırır.
Dijital sinyaller, parçaları analog sinyallerden daha uzun ömürlü hale getirir.

BAKIM DOSTU

Makine tasarımı ve kullanılan bileşenler servis ve bakımı kolaylaştırmak için uyarlanmıştır.
Ana kapağı yalnızca 2 vidayla çıkarırken tüm bileşenlere ulaşmak kolaydır.

SAĞLAM VE GÜVENİLİR TASARIM

- Güçlü 8 mm kalınlığında gövdeye sahip sağlam şasi, makine ve bileşenlerini dışarıdan mekanik darbelerle karşı korur.
- Güçlü metal akü kapağı ile birlikte makine, servis işini ve hasarları en aza indirmek için iyi bir donanıma sahiptir.
- Bileşenler ve fren doğrudan darbelerin erişemeyeceği bir yerde olduğundan, kirliliğin ortamlarının dikey AC motor tasarımı üzerinde daha az etkisi vardır.
- IP54 korumalı denetleyici, toza ve sıçrayan suya karşı güvenlidir.

ROYAL PT SERİSİ



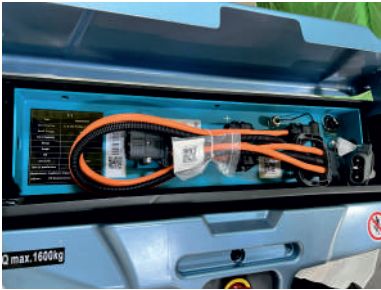
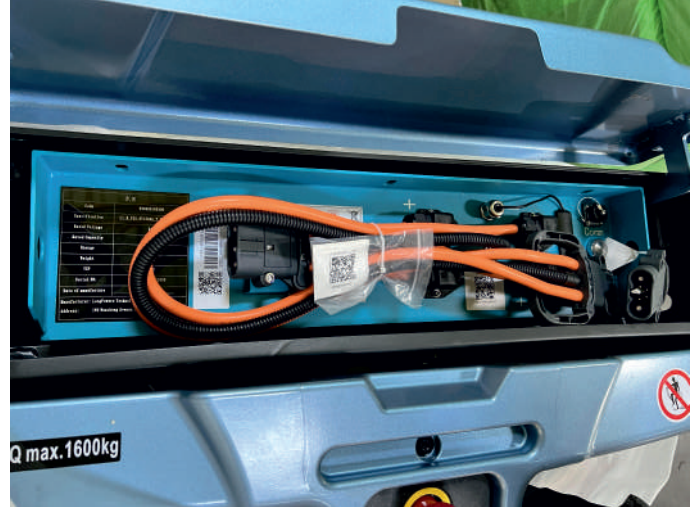

ROYAL TÜM ÜRÜNLERİNDE LİTYUM AKÜLERİ BİR STANDART OLARAK SUNAR.

ERGONOMİ VE GÜVENLİK İÇİN UZUN KOL TASARIMI



Özellikle uzun kol tasarımı sayesinde operatör, işi çok ergonomik bir şekilde yürütürken makineyle her zaman güvenli bir mesafeyi koruyabilir.

Kol çalışma yüksekliği doğal olarak ergonomik, operatör dostu kontrol konumlarına göre konumlandırılmıştır.



GİRİŞ

- -P16-25 serisi, 1600kg'dan 2500kg'a kadar kapasiteleri ile yükleme ve boşaltmada olduğu kadar kısa mesafelerde evrensel taşımacılıkta da ilk tercihtir.
- -Kısa şasi uzunluğu (P16) ile makine, kapalı alanlarda çalışacak şekilde tasarlanmıştır.
- -Makine, yüksek kaliteli ve son teknoloji üst marka bileşenleri ve teknolojileri ile pazardaki önde gelen tanınmış markalarla rekabet ediyor.

P 16/20

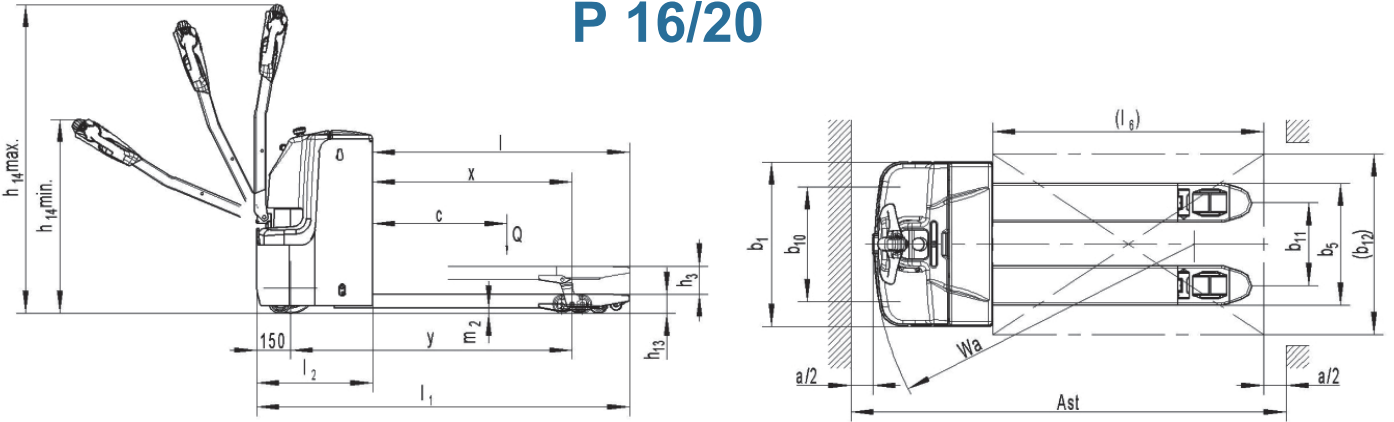

P 25

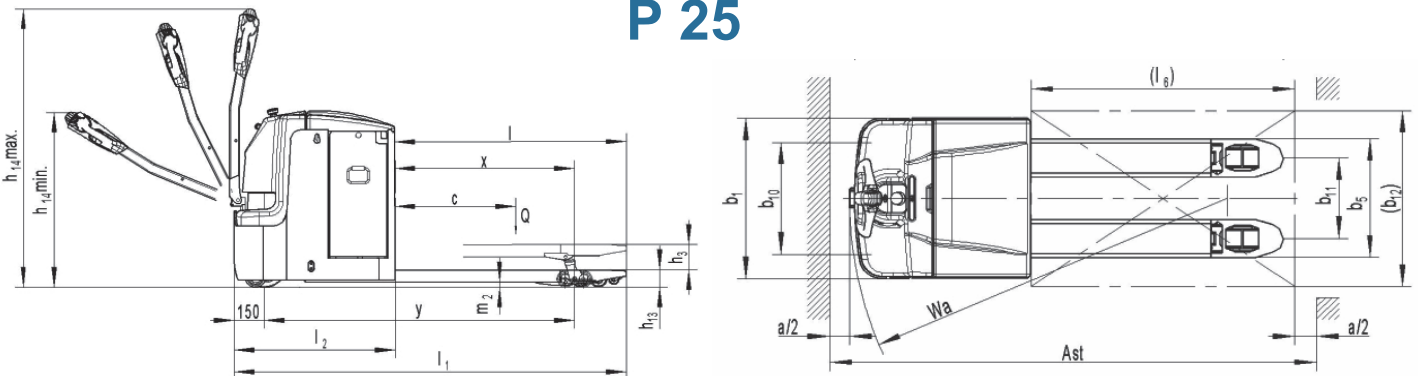

Royal Electric Rider Type

Distinguishing mark	1.2	Manufacturer's type designation	/
	1.3	Drive	/
	1.4	Operator type	/
	1.5	Load Capacity / rated load	Q(t)
	1.6	Load centre distance	c(mm)
	1.8	Load distance,centre of drive axle to fork	x(mm)
	1.9	Wheelbase	y(mm)
Weight	2.1	Service weight	kg
	2.2	Axle loading, laden front/rear	kg
	2.3	Axle loading, unladen front/rear	kg
Tires, chassis	3.1	Tires	/
	3.2	Tire size, front	Φx w(mm)
	3.3	Tire size, rear	Φx w(mm)
	3.4	Additional wheels(dimensions)	Φx w(mm)
	3.5	Wheels,number front/rear(x=driven wheels)	/
	3.6	Tread,front	b 10(mm)
	3.7	Tread,rear	b 11(mm)
Dimensions	4.4	Lift	h 3(mm)
	4.9	Height of tiller in drive position min./ max.	h 14(mm)
	4.15	Height lowered	h 13(mm)
	4.19	Overall length	l 1(mm)
	4.20	Length to face of forks	l 2(mm)
	4.21	Overall width	b 1(mm)
	4.22	Fork dimensions	s/e/l(mm)
	4.25	Width across forks	b 5(mm)
	4.32	Ground clearance, centre of wheelbase	m 2(mm)
	4.34	Aisle width for pallets 1000X1200 crossways	Ast(mm)
	4.34	Aisle width for pallets 800X1200 lengthways	Ast(mm)
	4.35	Turning radius	Wa(mm)
Performance data	5.1	Travel speed,laden/ unladen	km/h
	5.2	Lift speed, laden/ unladen	m/s
	5.3	Lowering speed, laden/ unladen	m/s
	5.8	Max. gradeability,laden/ unladen	%
	5.10	Service brake	/
Electric-engine	6.1	Drive motor rating S2 60min	kW
	6.2	Lift motor rating at S3 10%	kW
	6.3	Battery acc.to DIN 43531/35/36 A,B,C,no	/
	6.4	Battery voltage,nominal capacity K5	V / Ah
	6.5	Battery weight	kg
	6.6	Energy consumption acc.to VDI cycle	kWh/h
Additional data	8.1	Type of drive control	/
	8.4	Sound level at driver's ear acc.to EN 12053	dB(A)

Pallet Truck Data Sheet

P16S-T	P20S-T	P25S-T
Battery	Battery	Battery
Pedestrian	Pedestrian	Pedestrian
1.6	2.0	2.5
600	600	600
892	892	892
1261	1327	1541
445	535	720
715/1330	855/1680	1040/2200
345/100	415/120	540/200
Polyurethane (PU)	Polyurethane (PU)	Polyurethane (PU)
Φ230x70	Φ230x70	Φ230x70
Φ84x84	Φ84x84	Φ84x84
Φ100x40	Φ100x40	Φ100x40
1x+2/4	1x+2/4	1x+2/4
510	510	510
367/512	367/512	367/512
120	120	120
800/1335	800/1335	800/1335
85	85	85
1670	1735	1950
520	595	810
729	729	729
60/173/1150	60/173/1150	60/173/1150
540/685	540/685	540/685
25	25	25
1885	1955	2175
1935	2005	2225
1440	1490	1750
5.7/6.0	5.7/6.0	5.5/6.0
0.025/0.035	0.022/0.030	0.035/0.045
0.035/0.030	0.035/0.035	0.040/0.040
8/15	8/15	8/15
Electromagnetic	Electromagnetic	Electromagnetic
1.7	1.7	1.7
2.2	2.2	2.2
2VBS	2PZS	3PZS
160	210	350
150	215	285
0.44	0.39	0.92
AC speed control	AC speed control	AC speed control
67	69	65

Royal Electric Walkie Type

General Data	1.2	Manufacturer's type designation	/
	1.3	Power(battery,diesel,petrol gas>manual)	/
	1.4	Operator type	/
	1.5	Load Capacity / rated load	Q(t)
	1.6	Load centre distance	C(mm)
	1.8	Load distance, centre of drive axle to fork	x(mm)
	1.9	Wheelbase	y(mm)
Weight	2.1	Service weight	Kg
	2.2	Axle loading, laden front/rear	Kg
	2.3	Axle loading, unladen front/rear	Kg
Tires, chassis	3.1	Tires	/
	3.2	Tire size, front	ΦxW (mm)
	3.3	Tire size, rear	ΦxW (mm)
	3.4	Additional wheels(dimensions)	ΦxW (mm)
	3.5	Wheels, number front/rear(x=driven wheels)	/
	3.6	Tread, front	b10(mm)
	3.7	Tread, rear	b11(mm)
Dimensions	4.4	Lift height	h3 (mm)
	4.9	Height of tiller in drive position min. / max.	h14 (mm)
	4.15	Height, lowered	h13 (mm)
	4.19	Overall length	l1 (mm)
	4.20	Length to face of forks	l2 (mm)
	4.21	Overall width	b1 (mm)
	4.22	Fork dimensions	s/e/l (mm)
	4.25	Distance between fork-arms	b5 (mm)
	4.32	Ground clearance, centre of wheelbase	m2 (mm)
	4.33	Aisle width for pallets 1000 x 1200 crossways	Ast(mm)
	4.34	Aisle width for pallets 1000X1200 lengthways	Ast(mm)
	4.35	Turning radius	Wa (mm)
Performance	5.1	Travel speed, laden/ unladen	km/h
	5.2	Lift speed, laden/ unladen	m/s
	5.3	Lowering speed, laden / unladen	m/s
	5.8	Gradeability, laden/ unladen	%
	5.10	Service brake	/
Motors	6.1	Drive motor rating S2 60min	kw
	6.2	Lift motor rating at S3 10%	kw
	6.3	Battery acc. to DIN 43531/35/36 A, B, C, no	/
	6.4	Battery voltage, nominal capacity K5	V/Ah
	6.5	Battery weight	kg
	6.6	Energy consumption acc: to VDI cycle	kwh/h
Additional data	8.1	Type of drive control	/
	8.4	Sound level at driver's ear acc. to EN 12053	dB(A)

1) Load section lowered: +65 mm; 2) With side battery removal: + 30 mm; 3) With unfolded platform: + 440 mm

4) With 3VBS battery (up to 270 Ah): y = 1290 mm; l2 = 600 mm; Ast = 40 mm less; Wa = 40 mm less;

Pallet Truck Data Sheet

P20	P25
Battery	Battery
Pedestrian/Stand	Pedestrian/Stand
2.0	2.5
600	600
892 ¹⁾	892 ¹⁾
1330 ¹⁾²⁾⁴⁾	1435 ¹⁾
650	820
1110/1540	1370/1950
510/140	600/200
Polyurethane (PU)	Polyurethane (PU)
210×70	210×70
84×84	84×84
100×40	100×40
1x+2/4	1x+2/4
560	560
367/512	367/512
120	120
950/1350	950/1350
85	85
1790 ²⁾³⁾	1895
640 ²⁾³⁾⁴⁾	745 ³⁾
790	790
55/173/1150(2400)	55/173/1150(2400)
540/685	540/685
30	30
2400 ²⁾³⁾⁴⁾	2505 ³⁾
2290 ²⁾³⁾⁴⁾	2395 ³⁾
1585 ²⁾³⁾⁴⁾	1690 ³⁾
7.0/8.0	6.0/7.0
0.025/0.030	0.035/0.045
0.030/0.025	0.045/0.050
8/15	8/15
Electromagnetic	Electromagnetic
1.4	1.4
2.2	2.2
/	/
24/210 2PzS	24/350 3PzS
185	285
0.36	0.9
AC- speed control	AC- speed control
69	69

OPTİMUM VERİMLİLİK

- Yüksek kaliteli temel bileşenleri kullanma:
 - Ergonomik temassız basmalı anahtarlara sahip güvenilir çok işlevli REMA kol.
 - Schabmueller AC tahrik motoru.
 - ZAPI kartlar
 - Kordel şanzıman
 - HPI hidrolik güç paketi.(HPI hidrolik pompa)
 - Moment freni
 - Wicke tahrik tekerleği

Kullanılan parçalar yüksek servis maliyetlerini düşürür ve zorlu istifleme işlemleri için gereken performans ve güvenilirliği sağlar

ERGONOMİ VE GÜVENLİK İÇİN UZUN KOL TASARIMI.

- -Uzun kol tasarımı ile operatör, ergonomik olarak çalışırken makineden her zaman güvenli bir mesafeyi koruyabilir.
Kol çalışma yüksekliği doğal olarak ergonomik olacak şekilde monte edilmiştir ve operatöre kolay kontrol konumları sağlar.
 - Güvenli mesafe ve çatalların daha iyi görülmesi sayesinde istifleme işlemleri daha hızlı ve daha ekonomik hale gelir.
 - Yanlara monte edilmiş uzun 4 tekerlekli tasarım, çatallara tam ve mükemmel bir görüş sağlar.

ELEKTRİKLİ ORANTILI KALDIRMA VE İNDİRME

- Elektronik olarak kontrol edilen orantılı kaldırma sistemi, her Kaldırma yüksekliğinde doğru konumlandırma ve istifleme işlemleri sağlar.
Özellikle yüksek direklerde elektronik kontrollü orantılı kaldırma en iyi performansı gösterir.

CANBUS TEKNOLOJİSİ

- CANBUS teknolojisi, daha fazla güvenilirlikle daha az kablo bağlantısından kaynaklanmaktadır.
Bakım için CANBUS teknolojisi analizleri ve ayarlamaları kolaylaştırır, böylece arıza süresi CANBUS'suz makinelere göre daha düşüktür.
Dijital sinyaller ayrıca parçaların analog sinyallere göre daha uzun ömürlü olmasını sağlar.



ROYAL ELEKTRİKLİ İSTİFLEME

- -Ergonomik, kompakt ve güvenli uzun kol tasarımı.
- -Tam oransal hidrolik sistem ile hassas kaldırma ve indirme.
- -Güçlü, bakım gerektirmeyen Alman AC aktarma organı.
- -En kaliteli markalardan temel bileşenler.
- -Stabilite için 4 tekerlek yapısı.

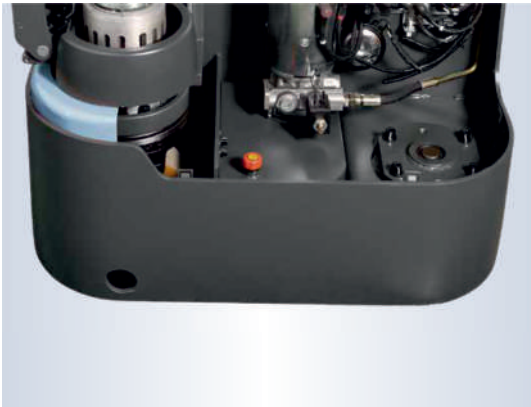

SAĞLAM VE GÜVENİLİR TASARIM

Güçlü 8 mm kalınlığında gövdeye sahip sağlam şasi, makine ve bileşenlerini çevreden gelen mekanik darbelerle karşı korur. Metal akü kapağı ile birlikte makine, bakım çalışmalarını ve hasarları en aza indirmek için iyi bir donanıma sahiptir.



ALMAN AC SÜRÜŞ TEKNOLOJİSİ

Alman Kordel dişli kutusu, Intorçe fren ve Wicke tahrik tekerleği ile bakım gerektirmeyen güçlü Alman Schabmueller AC Tahrik motoru hep birlikte en iyi performansı, verimliliği ve güvenilirliği sağlar; bu en iyi marka kombinasyonu, genel işletme maliyetini azaltır ! İster yumuşak ister ani hızlanma gerekli olsun, AC Sürücü her zaman doğru ve doğrudan yanıt verir



GİRİŞ

- -S 12-20L serisi, 1200kg'dan 2000kg'a kadar kapasitelerle kontrollü istifleme operasyonlarına uyarlanmıştır.
- -Uzun monte kol ile operatör, işini yapmak için güvenli ve ergonomik mesafeyi korur.
- -Hassas çalışan tam orantılı kaldırma sistemi sayesinde istifleme işlemleri daha güvenli ve hızlı hale gelir.
- -Makine, yüksek kaliteli ve son teknoloji üst düzey marka bileşenleri ve teknolojileri ile pazardaki önde gelen tanınmış markalarla rekabet eder.

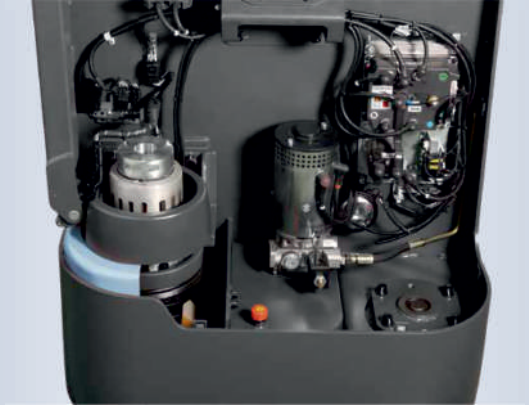

BAKIM DOSTU

- Makine tasarımı ve kullanılan bileşenler servis ve bakımı kolaylaştırmak için uyarlanmıştır.
- Ana bileşenlerine, yalnızca iki vidayla gövde kapağı çıkarıldıktan sonra kolayca erişilebilir.
- Tahrik tekerleği ve küçük tekerlek, makine kaldırmadan kolayca değiştirilebilir.

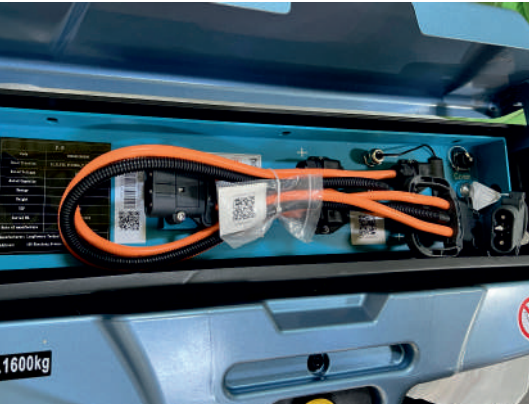

Royal tüm istifleme makinelerine Lityum aküyü bir standart olarak sunar.





Royal Electric Stacker

Distinguishing mark	1.2	Manufacturer's type designation	/	
	1.3	Power (battery,diesel, petrol, gas, manual)	/	
	1.4	Operator type	/	
	1.5	Load Capacity / rated load	Q (t)	
	1.6	Load centre distance	c (mm)	
	1.8	Load distance ,centre of drive axle to fork	x (mm)	
	1.9	Wheelbase	y (mm)	
Weight	2.1	Service weight	kg	
	2.2	Axle loading, laden front/rear	kg	
	2.3	Axle loading, unladen front/rear	kg	
Tires, chassis	3.1	Tires	/	
	3.2	Tire size, front	Φxw (mm)	
	3.3	Tire size, rear	Φxw (mm)	
	3.4	Additional wheels (dimensions)	Φxw (mm)	
	3.5	Wheels, number front/rear(x=driven wheels)	/	
	3.6	Tread, front	b10 (mm)	
	3.7	Tread, rear	b11 (mm)	
Dimensions	4.2	Lowered mast height	h1 (mm)	
	4.3	Free lift height	h2 (mm)	
	4.4	Lift height	h3 (mm)	
	4.5	Extended maximal height	h4 (mm)	
	4.9	Height of tiller in drive position min./ max.	h14 (mm)	
	4.15	Height, lowered	h13 (mm)	
	4.19	Overall length	l1 (mm)	
	4.20	Length to face of forks	l2 (mm)	
	4.21	Overall width	b1 (mm)	
	4.22	Fork dimensions	s/e/l (mm)	
	4.25	Distance between fork-arms	b5 (mm)	
	4.32	Ground clearance, centre of wheelbase	m2 (mm)	
	4.33	Aisle width for pallets 1000X1200 crossways	Ast (mm)	
	4.34	Aisle width for pallets 800X1200 lengthways	Ast (mm)	
	4.35	Turning radius	Wa (mm)	
Performance data	5.1	Travel speedl, laden unladen	km/h	
	5.2	Lift speed laden/ unladen	m/s	
	5.3	Lowering speed, laden/ unladen	m/s	
	5.8	Max gradeability, laden unladen	%	
	5.10	Service brake	/	
Electric-engine	6.1	Dirve motor rating S2 60min	kW	
	6.2	Lift motor rating at S3 4.5%	kW	
	6.3	Battery acc.to DIN 43531/35/36 A,B,C,no	/	
	6.4	Battery voltage,nominal capacity K5	V/Ah	
	6.5	Battery weight +/-5%	kg	
	6.6	Energy consumption acc: to VDI cycle	kWh/h	
Additional data	8.1	Type of drive control	/	
	8.4	Sound level at driver's ear acc.to EN 12053	dB(A)	

Walkie Type Data sheet

S12L(3600)	S12L(4600)	S16L(4600)	S20L(4600)
Battery	Battery	Battery	Battery
Pedestrian	Pedestrian	Pedestrian	Pedestrian
1.2	1.2	1.6	2.0
600	600	600	600
647	637	647	647
1248	1248	1293	1429
1007	1150	1340	1579
684/1523	735/1610	930/2010	1000/2579
610/397	720/430	850/490	900/679
Polyurethane(PU)	Polyurethane(PU)	Polyurethane(PU)	Polyurethane(PU)
Φ230x70	Φ230x70	Φ230x70	Φ230x70
Φ84x70	Φ84x70	Φ84x70	Φ84x70
Φ150x54	Φ150x54	Φ150x54	Φ150x54
1x+1/4	1x+1/4	1x+1/4	1x+1/4
522	522	522	522
390/505	390/505	390/505	390/505
2308	2108	2108	2228
1760	1520	1520	1520
3530	4530	4530	4530
4088	5088	5088	5208
850/1385	850/1385	850/1385	850/1385
90	90	90	90
1919	1929	1964	2100
769	779	814	950
820	820	820	820
60/180/1150	60/180/1150	60/180/1150	60/180/1150
570/685	570/685	570/685	570/685
28	28	28	23
2336	2346	2406	2536
2323	2333	2393	2523
1400	1400	1510	1640
6.0/6.0	6.0/6.0	5.7/6.0	5.4/6.0
0.09/0.14	0.13/0.20	0.13/0.20	0.13/0.20
0.25/0.20	0.28/0.23	0.28/0.23	0.28/0.23
6/12	6/12	6/12	6/10
Electromagnetic	Electromagnetic	Electromagnetic	Electromagnetic
/	1.3	1.3	1.7
1.5	3.2	3.2	3.2
2VBS	2VBS	3VBS	3PZS
24/180	24/180	24/270	24/350
175	175	230	288
0.95	0.95	1.59	1.70
AC-Speed control	AC-Speed control	AC-Speed control	AC-Speed control
<70	<70	<70	<70

Royal Electric Stacker

Distinguishing mark	1.2	Manufacturer`s type designation	/	
	1.3	Power (battery ,diesel, petrol, gas, manual)	/	
	1.4	Operator type	/	
	1.5	Load Capacity / rated load	Q(t)	
	1.6	Load centre distance	C(mm)	
	1.8	Load distance ,centre of drive axle to fork	x(mm)	
	1.9	Wheelbase	y(mm)	
Weight	2.1	Service weight	Kg	
	2.2	Axle loading, laden front/rear	Kg	
	2.3	Axle loading, unladen front/rear	Kg	
Tires, chassis	3.1	Tires	/	
	3.2	Tire size, front	Φxw (mm)	
	3.3	Tire size, rear	Φxw (mm)	
	3.4	Additional wheels(dimensions)	Φxw (mm)	
	3.5	Wheels, number front/rear(x=driven wheels)	/	
	3.6	Track, front	b10(mm)	
	3.7	Track, rear	b11(mm)	
Dimensions	4.2	Lowered mast height	h1(mm)	
	4.3	Free Lift height	h2(mm)	
	4.4	Lift height(up to)	h3(mm)	
	4.5	Extended mast height	h4(mm)	
	4.9	Height of tiller in drive position min./ max.	h14(mm)	
	4.15	Height, lowered	h13(mm)	
	4.19	Overall length	l1(mm)	
	4.20	Length to face of forks	l2(mm)	
	4.21	Overall width	b1(mm)	
	4.22	Fork dimensions	s/e/l(mm)	
	4.25	Distance between fork-arms	b5(mm)	
	4.32	Ground clearance, centre of wheelbase	m2(mm)	
	4.33	Aisle width for pallets 1000X1200 crossways	Ast(mm)	
	4.34	Aisle width for pallets 800X1200 lengthways	Ast(mm)	
	4.35	Turning radius	Wa(mm)	
Performance data	5.1	Travel speed, laden/ unladen	km/h	
	5.2	Lift speed, laden/ unladen	m/s	
	5.3	Lowering speed, laden/ unladen	m/s	
	5.8	Max. gradeability, laden/ unladen	%	
	5.10	Service brake	/	
Electric- engine	6.1	Drive motor rating S2 60min	kw	
	6.2	Lift motor rating at S3 10%	kw	
	6.3	Battery acc. to DIN 43531/35/36 A, B, C, no	/	
	6.4	Battery voltage, nominal capacity K5	V/Ah	
	6.5	Battery weight	kg	
	6.6	Energy consumption acc: to VDI cycle	kWh/h	
Additional data	8.1	Type of drive control	/	
	8.4	Sound level at driver`s ear acc. to EN 12053	dB(A)	

1) With unfolded platform: + 440 mm

Rider Type Data sheet

S 12L-T(3600)	S 16L-T(5500)	S 20L-T(4600)
Battery	Battery	Battery
Pedestrian/Stand	Pedestrian/Stand	Pedestrian/Stand
1.2	1.6	2
600	600	600
647	647	647
1167	1215	1327
1080	1380	1620
860/1420	1040/1940	1210/2410
780/320	940/440	1090/540
Polyurethane (PU)	Polyurethane (PU)	Polyurethane (PU)
Φ230x70	Φ230x70	Φ230x70
Φ85x75	Φ85x75	Φ85x75
Φ150x54	Φ150x54	Φ150x54
1x+1/4	1x+1/4	1x+1/4
510	510	510
390/505	390/505	390/505
2308	2410	2228
1760	1820	1520
3530	5430	4530
4088	6110	5208
950/1350	950/1350	950/1350
90	90	90
1855 1)	1896 1)	2025 1)
705 1)	746 1)	875 1)
790	790	790
60/180/1150	60/180/1150	60/180/1150
570/685	570/685	570/685
28	28	23
2285 1)	2325 1)	2455 1)
2250 1)	2290 1)	2420 1)
1380 1)	1420 1)	1550 1)
7.0/8.0	7.0/8.0	6.0/7.0
0.09/0.14	0.13/0.20	0.13/0.20
0.25/0.20	0.28/0.23	0.28/0.23
6/12	6/12	6/12
Electromagnetic	Electromagnetic	Electromagnetic
1.4	1.4	1.4
1.5	3.2	3.2
2VBS	3VBS	3PZS
24/180	24/240	24/350
175	230	288
0.95	1.34	1.7
AC- speed control	AC- speed control	AC- speed control
<70	<70	<70

Mast table S12L/S16L/S20L

Designation	Lowered mast height h1(mm)	Free lift height h2(mm)	Lift height h3(mm)	Extended mast height h4(mm)	Lift+fork height h3+h13(mm)
S12L					
Two-stage mast	1958	-	2830	3380	2920
Two-stage mast	2108	-	3130	3680	3220
Two-stage mast	2308	-	3530	40880	3620
Two-stage mast FFL (Full-Free-Lift)	1958	1410	2830	3380	2920
Two-stage mast FFL (Full-Free-Lift)	2108	1560	3130	3680	3220
Two-stage mast FFL (Full-Free-Lift)	2308	1760	3530	4080	3620
Three-stage mast FFL (Full-Free-FFL)	1998	1320	3930	4480	4020
Three-stage mast FFL (Full-Free-FFL)	2008	1420	4230	4780	4320
Three-stage mast FFL (Full-Free-FFL)	2108	1520	4530	5080	4620
S16L					
Two-stage mast	1985	-	2830	3380	2920
Two-stage mast	2108	-	3130	3680	3220
Two-stage mast	2308	-	3530	4080	3620
Two-stage mast FFL (Full-Free-Lift)	1958	1410	2830	3380	2920
Two-stage mast FFL (Full-Free-Lift)	2108	1560	3130	3680	3220
Two-stage mast FFL (Full-Free-Lift)	2308	1760	3530	4080	3620
Three-stage mast	2008	-	4230	4780	4320
Three-stage mast	2108	-	4530	5080	4620
Three-stage mast FFL (Full-Free-FFL)	1708	1120	3330	3880	3420
Three-stage mast FFL (Full-Free-FFL)	1908	1320	3930	4480	4020
Three-stage mast FFL (Full-Free-FFL)	2008	1420	4230	4780	4320
Three-stage mast FFL (Full-Free-FFL)	2108	1520	4530	5080	4620
Three-stage mast FFL (Full-Free-FFL)	2343	1756	5230	5780	5320
Three-stage mast FFL (Full-Free-FFL)	2408	1820	5430	5980	5520
S20L					
Two-stage mast	2078	-	2830	3500	2920
Two-stage mast	2228	-	3130	3800	3220
Two-stage mast	2428	-	3530	4200	3620
Two-stage mast FFL (Full-Free-Lift)	1798	1310	2630	3300	2720
Two-stage mast FFL (Full-Free-Lift)	2078	1410	2830	3500	2920
Two-stage mast FFL (Full-Free-Lift)	2228	1560	3130	3800	3220
Two-stage mast FFL (Full-Free-Lift)	2428	1760	3530	4200	3620
Three-stage mast	2128	-	4230	4900	4320
Three-stage mast	2228	-	4530	5200	4620
Three-stage mast FFL (Full-Free-FFL)	1978	1310	3930	4600	4020
Three-stage mast FFL (Full-Free-FFL)	2128	1420	4230	4900	4320
Three-stage mast FFL (Full-Free-FFL)	2228	1520	4530	5200	4620

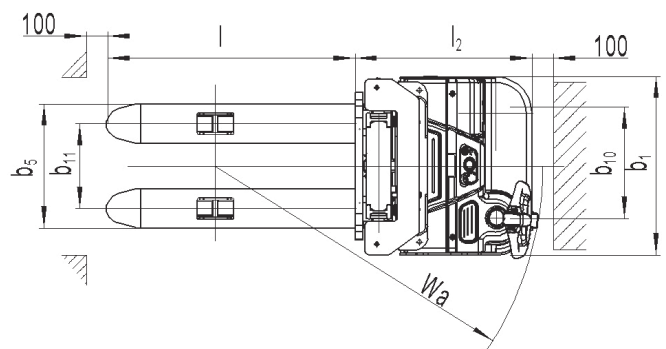
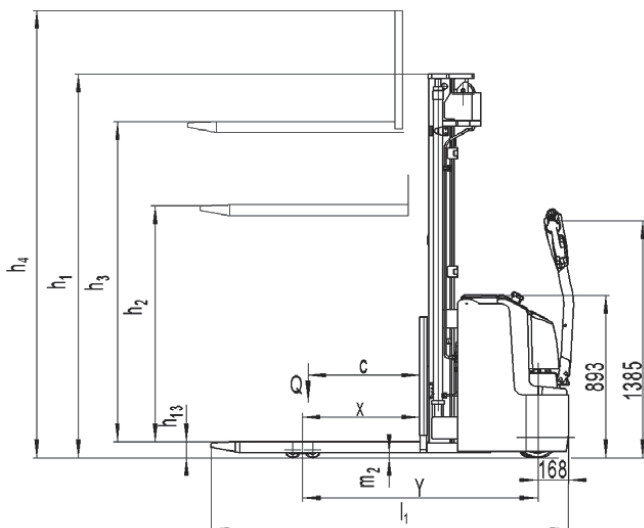

Mast table S 12L-T/16L-T/20L-T

Type	Lowered mast height h1(mm)	Free Lift height h2(mm)	Lift height h3(mm)	Extended mast height h4(mm)	Lift+fork height h3+h13(mm)
S 12L-T					
Two stage mast	1958	-	2830	3380	2920
Two stage mast	2108	-	3130	3680	3220
Two stage mast	2308	-	3530	4080	3620
Two stage mast FFL (Full-Free-Lift)	1958	1410	2830	3380	2920
Two stage mast FFL (Full-Free-Lift)	2108	1560	3130	3680	3220
Two stage mast FFL (Full-Free-Lift)	2308	1760	3530	4080	3620
S 16L-T					
Two stage mast	1958	-	2830	3380	2920
Two stage mast	2108	-	3130	3680	3220
Two stage mast	2308	-	3530	4080	3620
Two stage mast FFL (Full-Free-Lift)	1958	1410	2830	3380	2920
Two stage mast FFL (Full-Free-Lift)	2108	1560	3130	3680	3220
Two stage mast FFL (Full-Free-Lift)	2308	1760	3530	4080	3620
Three stage mast	2008	-	4230	4780	4320
Three stage mast	2108	-	4530	5080	4620
Three stage mast FFL (Full-Free-Lift)	1708	1120	3330	3880	3420
Three stage mast FFL (Full-Free-Lift)	1908	1320	3930	4480	4020
Three stage mast FFL (Full-Free-Lift)	2008	1420	4230	4780	4320
Three stage mast FFL (Full-Free-Lift)	2108	1520	4530	5080	4620
Three stage mast FFL (Full-Free-Lift)	2343	1756	5230	5780	5320
Three stage mast FFL (Full-Free-Lift)	2410	1800	5430	6110	5520
S 20L-T					
Two stage mast	2078	-	2830	3500	2920
Two stage mast	2228	-	3130	3800	3220
Two stage mast	2428	-	3530	4200	3620
Two stage mast FFL (Full-Free-Lift)	1978	1310	2630	3300	2720
Two stage mast FFL (Full-Free-Lift)	2078	1410	2830	3500	2920
Two stage mast FFL (Full-Free-Lift)	2228	1560	3130	3800	3220
Two stage mast FFL (Full-Free-Lift)	2428	1760	3530	4200	3620
Three stage mast	2128	-	4230	4900	4320
Three stage mast	2228	-	4530	5200	4620
Three stage mast FFL (Full-Free-Lift)	1978	1310	3930	4600	4020
Three stage mast FFL (Full-Free-Lift)	2128	1420	4230	4900	4320
Three stage mast FFL (Full-Free-Lift)	2228	1520	4530	5200	4620

